



LGR165L Dehumidifier After Water Damage

Preair LGR165 vertical dehumidifier has a fast dehumidification speed and can be operated simply and conveniently. It can control air humidity so that your enterprise production will not be affected by damp and dirty moisture, and your home will be free from humidity and mold. For post-disaster reconstruction, Preair [LGR165L dehumidifier after water damage](#) with high efficiency and dehumidifying capacity will be your best choice. Your inquiry is welcomed by Preair.



Specifications of LGR165L Dehumidifier For Flood

NO.	LGR165L
Power	115V/60Hz
Rated Current (A)	9.8
Power (W)	1085
Dehumidification Capacity/24Hrs	280 PPD/Day (30°C/80%RH) 165 PPD/Day (26.7°C/60%RH) 19 PPD/Day (40°C/20%RH) 350 PPD/Day (32°C/90%RH)
Operating Temperature Range	41°F -100.4°F
Operating Humidity Range	20%RH-90%RH
Body Size	560*589*842mm 22*23*33 in
Packaging Dimensions	690*640*880mm 27*25*34.6 in
Net Weight	124.5bs 56.5kg
Refrigerant	R410A/45.9oz
Housing	Water pump
Display Panel	LCD liquid crystal
20GP / 40GP / 40HQ	54*162*108
Filter	SUS304
Drain Pipe Length	6M



Structure of LGR165L Dehumidifier After Water Leak

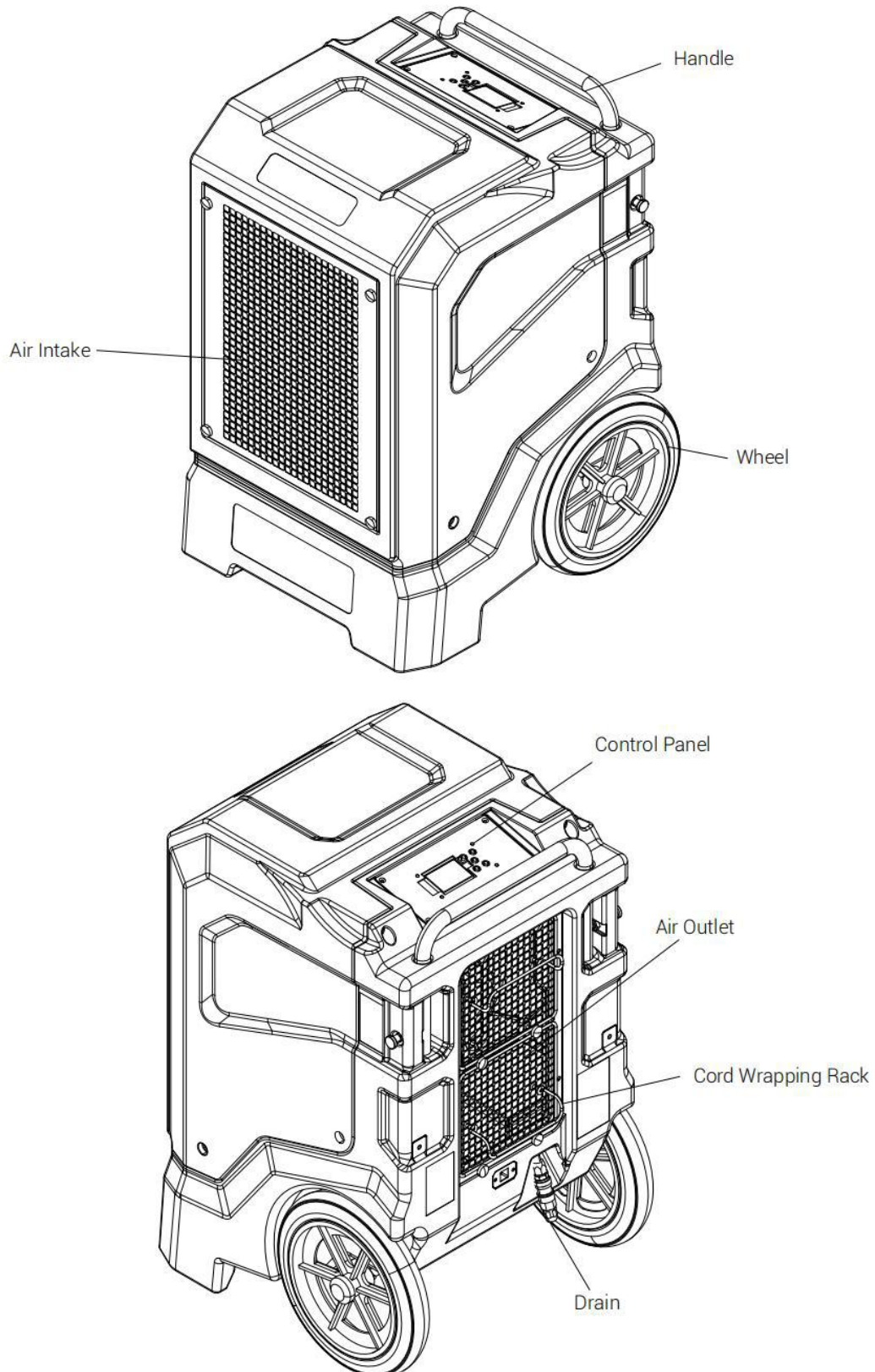



🏠 Applications of LGR165L Dehumidifier

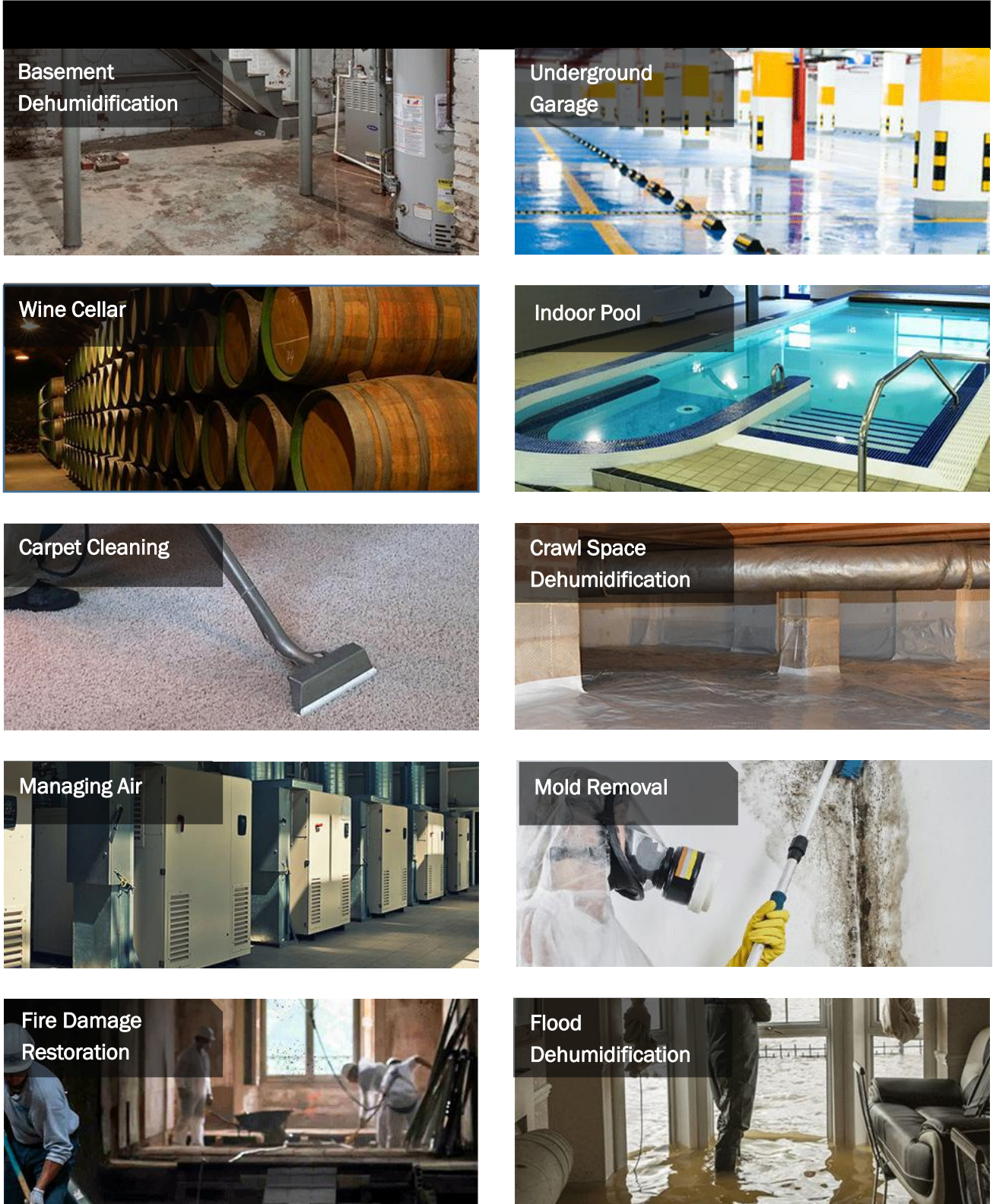



Water Damage Restoration



Construction



Hospital and Healthcare Facilities



Janitorial and Sanitation



Agriculture



Distribution and Logistics



Energy and Utilities



Industrial and Manufacturing



Science and Technology



Sports and Recreation

